

Camp Skinny:

FILM Bootcamp is a "hands-on" course in digital filmmaking. In this fun, creative and technical course we explore all aspects of digital filmmaking, from preproduction storyboarding and shot planning, to post production and editing. Students will learn about creating strong visual stories and how to achieve the most out of the digital cameras. They will also be introduced to visual effects such as laser blasts, green screening, and other compositing techniques; all with the goal of creating a complete short film. Students will write, film, act in, and edit their own digital film production!

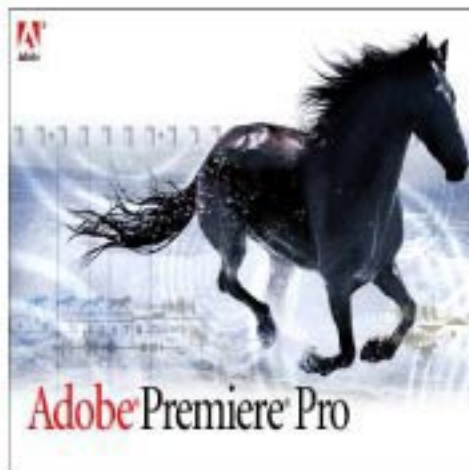

Premiere Pro by Adobe

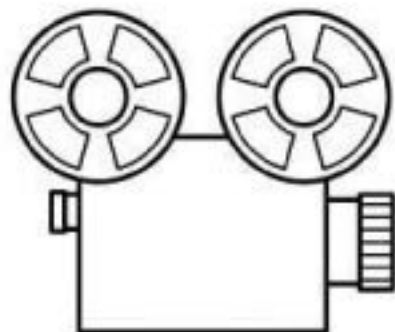

MediaFineArts.com
presents:
FILM Bootcamp

By Brent Phillips-Watts

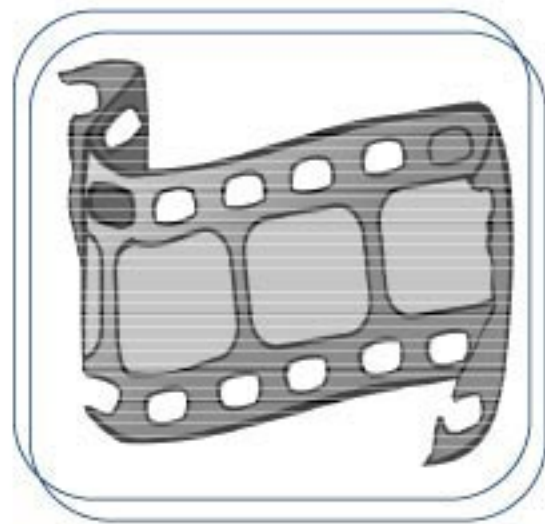

Film Bootcamp

Phone: 604-754-7726
mikeschoenhals@mediafinearts.com



Equipment and Software:

Canon FS200

- Students will learn how to use the manual functions of the cameras in order to get the best results from their equipment
- Digital media means fast transfer to the editing computers

Adobe Premiere Pro

- Award winning, professional level non-linear editing software.
- Easy to use for high quality results
- Available for PC and Mac

Adobe After Effects

- Industry leading visual effects software

We are excited to be offering our new Film Bootcamp to students between the ages of 8-14. This hands-on, practical camp will take beginner film makers through all of the aspects they need to make a complete digital film!

Our Film Bootcamp is an excellent starting place for students who want to learn about digital film making, but it's also a great place for students who already have some experience with film and editing. Both beginner and advanced level students will find this course challenging and fun!

Our Film Bootcamp only runs during the summer. Participants use Digital cameras and learn how to edit, apply effects, and export their finished films. During the camp, all students will plan, shoot, edit and complete a short digital film!



What's Covered:

The course will cover all of the basics to get you proficient with digital camera use, composition, non-linear editing, and basic visual effects.

Camp Outline at a glance:

1. Basics of Composition and Camera
 - Rule of Thirds
 - Manual camera functions
 - Equipment safety
2. Story Design
 - Concept Creation
 - Storyboarding
 - Props
3. Production
 - Role of the Director
 - Classic Coverage
 - Acting for Film
4. Editing
 - Titling
 - Editing for Narrative
 - Music
 - Sound Effects
5. Special/Visual Effects
 - Green screen techniques
 - Compositing techniques
6. Publishing
 - Exporting to Media

The above outline is a general overview used for the Film Bootcamp. This outline may vary depending on the needs of camp participants.

Time, Cost & Location:

The Summer Film Bootcamp runs from July 11 to 15, 2016

The cost of the Film Bootcamp is \$180.00

All camps are held at the Port Moody Arts Centre.

About the Instructor:

Brent Phillips-Watts has been teaching Film for 5 years in the Coquitlam district and currently teaches both film and Drama at Port Moody Secondary School.

To Register:

Registration is done through the Port Moody Arts Centre website. See the link on our site or go to: www.pomoarts.com



Instructor:
Brent Phillips-Watts
1300 David Ave
Port Moody

Phone: 604-754-7726
E-mail: ms@mediafinearts.com